

TLOCRT - POSTOJEĆE STANJE

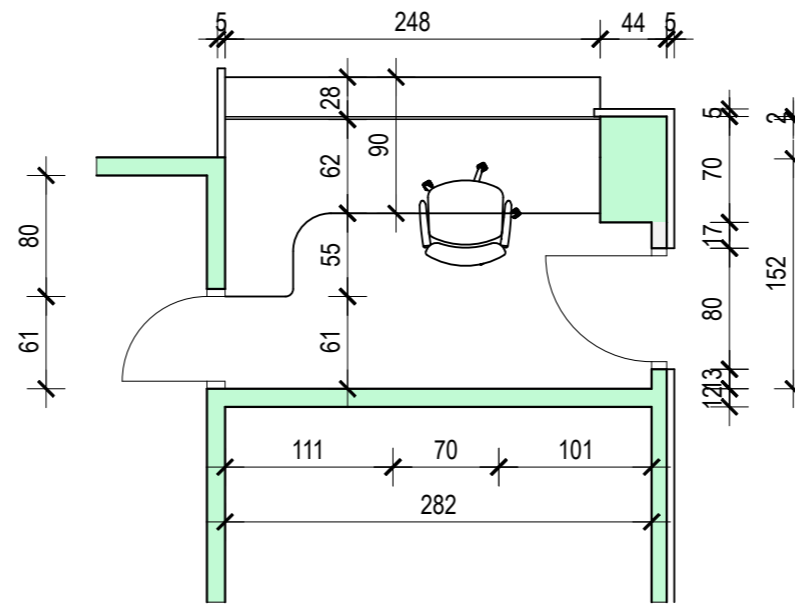

TLOCRT - NOVO STANJE

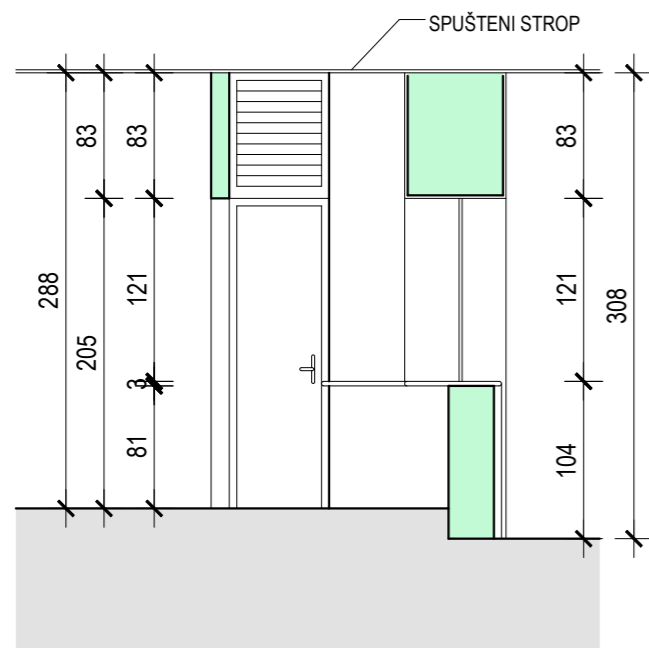
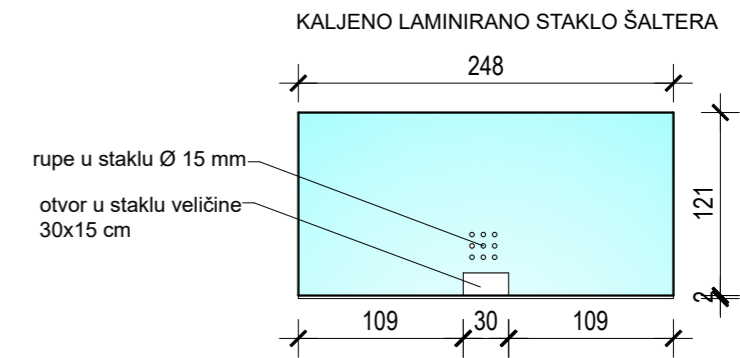

PRESJEK - POSTOJEĆE STANJE

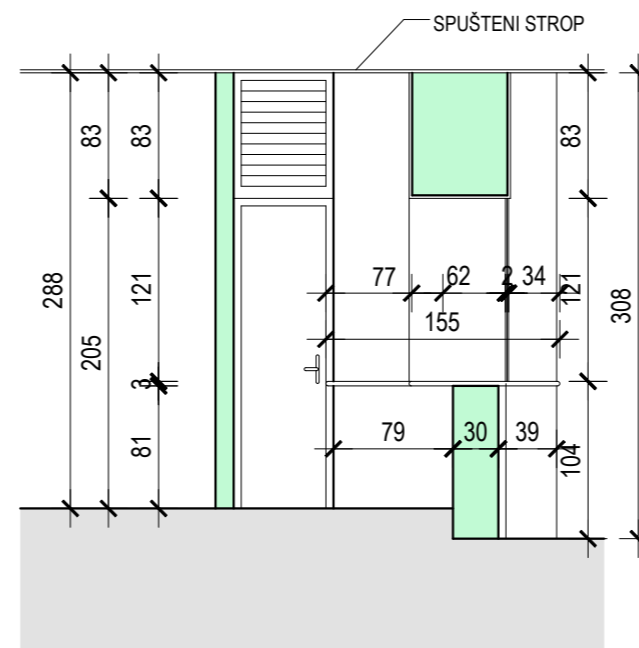

PRESJEK - NOVO STANJE

CENTURIO d.o.o. Rijeka Ive Marinkovića 12 51 000 RIJEKA		Ured Rijeka, Ive Marinkovića 12 tel. 051/330-043 fax. 051/330-414	
faza: TEHNIČKO RJEŠENJE UREDENJE ŠALTERA U PRIZEMLJU ZGRADE NZZJZ PGŽ-a u Rijeci, Krešimirova 52A		mjerilo: 1:50	
investitor: NASTAVNI ZAVOD ZA JAVNO ZDRAVSTVO PGŽ RIJEKA, KREŠIMIROVA 52 A			
naziv građevine: UREDENJE SALE ZA SASTANKE			
sadržaj: TLOCRT I PRESJEK ŠALTERA			
projektant: Zoran Dragin, ing.građ.			
t.d. 028 -24	ZOP: NZZJZ - 28-24	datum/godina 05/2024	list br. 1